

Fischer Panda® 15 Digital Panel AC Marine Generator

The Fischer Panda Generators are the ideal choice for the professional sailor or power boater. **When space is tight, weight is critical or noise is an issue, many boaters choose Fischer Panda.** The Fischer Panda 15 Digital Panel AC (60Hz) marine generator is powered by the reliable freshwater-cooled Kubota three-cylinder diesel engine and our superior asynchronous water-cooled alternator.

All Fischer Panda generators come standard with 100% freshwater cooling, superior sound enclosure, bulkhead external connections, remote fuel lift pump and remote-control panel.

Depending upon the kilowatt size Fischer Panda Generators can weigh up to 50% less than a conventional generator and are up to 30% smaller in size.



Fischer Panda®



SMALL



LIGHT



QUIET

351 S. Andrews Ave., Pompano Beach, FL 33069

Call (800) 508-6494

Visit us at www.fischerpanda.com

or e-mail us at sales@fischerpanda.com



FEATURES INCLUDE:

- Less weight, size and noise
- Extremely quiet (54dba@7meter)
- Direct driven fresh water-cooled Asynchronous Alternator
- Robust three-cylinder Kubota diesel engine
- Integrated internal booster enabling high inductive load starting
- Gear driven raw water pump
- Safety shutdowns for all critical functions
- Self-protected against overload
- Ignition protection for gas powered boats
- Comes complete with harnesses, remote-control panel, sound enclosure and remote fuel lift pump
- 5 Year limited warranty



Fischer Panda® 15 Digital Panel Specifications (60Hz)

| | |
|----------------------------|----------------------|
| Frequency (Hz) | 60 |
| Voltage (V) | 120/240 |
| Power Nominal (kW) | 13.7 |
| Current (Amp) | 114/57 |
| Engine Data | Kubota D902 |
| Cylinder/Hp | 3 cyl/24.8 |
| Displacement | 898 ccm/54.08 cu.in. |
| Cooling | Heat Exchanger |
| Noise Level dBa @ 7 meters | 54 |
| Length Inches | 29.13 |
| Width Inches | 21.5 |
| Height Inches | 23.97 |
| Weight (Wet) lbs. | 535 |

Rev. 01/15/2025. Fischer Panda Generator is standard with a sound shield.

Digital Panel

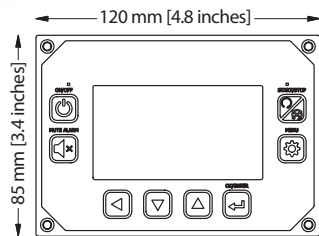

OPTIONAL ACCESSORIES

External Soft Motor Mounts
External Soft Motor Mounts for extra smooth operation.



Vented Loop
(anti-siphon valve) Recommended for all installations. Prevents water from siphoning back to the engine and minimizes potential electrolysis. Made with a stainless-steel tube and nylon valve for long life and easy service.



Gas Separator
Exhaust water separator provides very low back pressure and extra quiet exhaust noise.



Low Profile Muffler
Low inlet muffler for installations where the muffler cannot be installed lower than the genset.

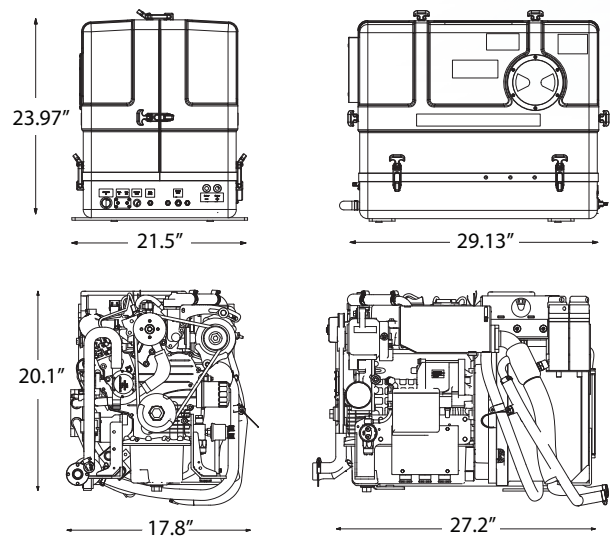

Fischer Panda®

351 S. Andrews Ave., Pompano Beach, FL 33069

Call (800) 508-6494

Visit us at www.fischerpanda.com
or e-mail us at
sales@fischerpanda.com

